



**“Making supply simple”**



**MINING, QUARRY, AGGREGATES  
MACHINERY & SPARE PARTS  
CONSTRUCTION EQUIPMENTS  
ELECTRICAL COMPONENTS  
ELECTRICAL CONDUITS &  
ACCESSORIES  
ELECTRICAL GROUNDING  
SYSTEM  
WELDING RODS & FILLERS  
POWER TOOLS  
ROAD MARKINGS, EQUIPMENTS  
AND SAFETY**

**INDUSTRIAL SUPPLY AND CONSTRUCTION**

**COMPANY  
PROFILE**

**PARTNER  
WITH US**

[www.arditechcorp.com](http://www.arditechcorp.com)

**COMPANY HISTORY**

Arditech Corporation (AC) established in 2018 as a sole proprietorship and by the grace of God, in 2020 it expands to Corporation. By 2023, board of directors decided to expand the company with **installation, repair and maintenance services for processing machinery equipment's and construction for civil works, mechanical and electrical works.**



AC supplies quality and promoting only reputable brands of Industrial Products such as Construction Equipment, Mining, Quarry, Aggregates and Industrial Processing Machinery and Equipment, Electrical and Accessories, Power Tools, Power Generation Hardware and Accessories, to serve a broad range industry in Construction, Mining Plant, Milling Plant, Quarry Plant, Aggregate Plant, Batching Plant, Steel Plant, Power and Generating Stations, Oil and Gas, Semi-Conductor, Food and Beverage and other Manufacturing Plants.

While newly establish company, from the first successfully supplied up to today we serve our clients the most competitive price and the best service. For repair, maintenance and construction, We ensure to have longevity of our company through repeat and referral business achieved by customer satisfaction in all areas.



## OUR COMMITMENT

Our commitment to client is to provide the best solution to the client's requirements, to build long term relationship with all our client's, performing ethical and transparent practices in all business activities.

We also exceed the client's expectation in all areas of business. Most of all we train our people to build a loyal team, and treat individuals with respect and dignity. And by the guidance of God, we treat each person at work with grace and love.

### OUR MISSION

- To accommodate the customers need by being responsive
- To deliver amazing service
- To be the preeminent provider of superior construction
- To build customers trust
- To have a long term relationship with all our client's

### OUR VISION

- To be the leading industrial supplies by providing reputable brand and competitive price and the best solution to the client's requirements.
- To improve more on our services by extend the R&D in Machinery and Construction
- To develop high performing people that deliver successful projects.

### OUR VALUES

- Preserve the trust, loyalty, integrity and accountability in our services.
- Respect and Dignity
- God Fearing Team

## OUR PRODUCTS FOR SUPPLIES



Electrical Components, Electrical Conduit and Fittings, Strut Channel, Wire Mesh Cable Tray and Cable Ladder, Welding Rods, Stone Crusher Equipments, Screening and Classifying, Grinding Mill Equipments, Construction Equipments and Concrete Batching Plant

## OUR BRANDS AND PARTNERS FOR SUPPLIES





**Mobile Asphalt Mixer**  
 Burner is available for coal and oil.  
 Capacity: 1 to 1.5 ton / batch, 10-15 times  
 Insulation Roller Volume: 3.88m<sup>3</sup> / 5m<sup>3</sup>  
 Mixer Drum Mat'l: Double-Layer Manganese Plate  
 Actual Drum Agitation: 0.9-1m<sup>3</sup> / 0.7-0.8m<sup>3</sup>



**Mobile Concrete Mixing with Drum**  
 Convenient movement  
 Capacity: 25 – 75m<sup>3</sup>h  
 Discharging Height: 1600mm  
 Mixing System Discharging Vol: 500 -1500L  
 Max Aggregate Dia (pebble/gravel): 60/80mm  
 Trailer Speed: 40-60km/h



**Mobile Concrete Batching Plant**

1. Quick disassembling, move convenient.
2. Other properties and operating mode, principle are same with fixed standard station.  
 Capacity: 25 – 75m<sup>3</sup>h  
 Discharging Height: 1600mm  
 Mixing Discharging Capacity: 0.5 – 1.5m<sup>3</sup>  
 Max Aggregate Dia (pebble/gravel): 60/80mm  
 Trailer Speed: 40km/h



**Stationary Concrete Batching Plant**

Ideal choice to produce high quality concretes  
 Capacity: 25 – 180m<sup>3</sup>h  
 Mixing Discharging Capacity: 500 – 3000L  
 Max Aggregate Dia (pebble/gravel): 60/80mm  
 Powder Storage – Detachable Silo: 100T / 160T / 200T  
 Conveyor: Screw and Belt  
 Air System: Air Compressor  
 Electrical Control: PLC control system, control console, weak & heavy current regulator



**Stabilized Soil Mixing Station**

new type of movable cement mixing plant  
 Capacity: 200 – 600t/h  
 Max Aggregate Dia (pebble/gravel): 60mm  
 Aggregate Weighing Accuracy: ±3%(Volume), ±2%(Electronics)  
 Powder weighing accuracy: ±2%(Volume), ±1%(Electronics)  
 Water weighing accuracy: -1~+2%

**BLOCK MAKING MACHINE**

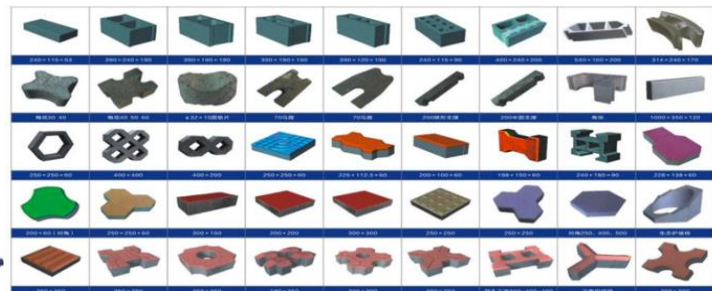

# CRUSHING & GRINDING EQUIPMENTS



## Jaw Crusher

Feed Opening:  
150-1500mm  
Max Feeding Size:  
125 - 1200mm  
Adjusting Range of  
discharge opening:  
10-350mm  
Capacity: 1-1000 tph



## SC Cone Crusher

Stroke – 12-34 mm  
Max Feeding Size:  
50-360 mm  
Crusher Running at  
CSS: 6-64mm  
Capacity: 50 -725 tph



## Spring Cone Crusher

Max Input: 35-300mm  
Adjusting Range of  
Output: 3-60mm  
Capacity: 5-1000tph  
Power: 30-280kW



## Single Cylinder Hydraulic Cone Crusher

Max Feeding Size:  
135-560 mm  
Crusher Running at CSS:  
45-1050mm



## Multi Cylinder Hydraulic Cone Crusher

Max Feeding Size:  
95-330 mm  
Crusher Running at  
CSS:  $\geq 10 - \geq 38$



## Impact Crusher

Feed Opening:  
400-2040 mm  
Max Feed Size:  
300-1200 mm  
Capacity: 30-800 tph  
Power: 37 – 650kW



## Hammer Crusher

Feed Opening Size:  
850-1400mm  
Feeding Size:  
 $\leq 700 - \leq 1300$   
Capacity: 100-500tph  
Output Size:  $< 30$   
Power: 132 – 250kW



## Mobile Jaw Crusher

Feed Opening Size:  
435-630mm  
Discharge Opening:  
50-180mm  
Capacity: 45-210tph  
Frame Configuration: 2-3  
Axle



## Mobile Cone Crusher

Feed Opening Size:  
160-235mm  
Discharge Opening:  
13-45mm  
Capacity: 50-220tph  
Frame  
Configuration: 2-3 Axle



## Mobile Crushing & Screening

Jaw Crusher  
Cone Crusher  
Vibrating Feeder  
Belt Conveyor  
Vibrating Screen  
Configuration: 3 Axle



## VSI Sand Maker

Feed Opening:  
35 – 45 mm  
Capacity: Ring &  
Center 120-500tph  
Center 60-350



## Reversible Sand Maker

Feed Size:  $< 50 - < 100$   
Capacity: 30-220tph



## Ball Mill

Feed Size:  $< 20 - < 25$   
Output Size:  
0.075 – 0.4mm  
Capacity: 0.65-6 tph



## Raymond Mill

Max Input Size : 30mm  
Final Size : 80-325 Mesh  
Total Power 382KW  
Capacity (According To  
The Fineness Of Different  
Materials): 6-28t/H

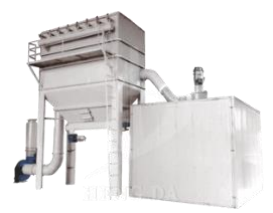

## Ultra Fine Mill

Type Mineral Ore  
Making  
Input Size : 0-20mm  
Final Product Size: 600-  
2500mesh (5-23micron)

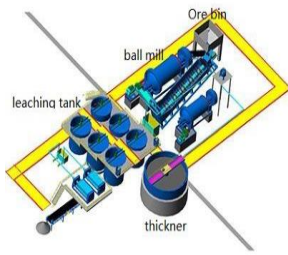

**Gold Ore Separation**  
**Carbon pulp method (CIP):** cyanide leaching is done first, then activated carbon is used to adsorb gold in the pulp;  
**Carbon leaching method (CIL):** activated carbon is added to the leaching tank, and leaching and adsorption are carried out simultaneously, that is, soaking and sucking.

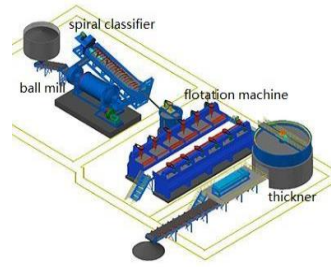

**Copper Ore Separation**

Copper Ore Flotation Process

Copper Ore Gravity Separation Process

**SCREENING AND CLASSIFYING**



**Vibrating Feeder**  
 Max Feed Size: 250 – 800 mm  
 Capacity: 80-1500tph  
 Obliquity of material through: 0 - 25°



**Vibrating Screen**  
 Max Feed Size: 400 mm  
 Capacity: 8 – 800 m3h  
 Mesh Size: 4 – 100  
 Sieve Layer: 2 - 4



**Linear Vibrating Screen**  
 Mesh Size: 0.074 – 15 mm  
 Amplitude: 4 – 10  
 Layers: 1 - 5



**Trommel Screen**  
 Trommel Diameter: 600 - 2500  
 Capacity: 1 - 150 m3h  
 Trommel Length: 2 – 12m  
 Aperture Size: 5 – 90 mm



**Roller Sieve & Drum Screen**  
 Trommel Diameter: 600 - 2500  
 Capacity: 1 - 150 m3h  
 Trommel Length: 2 – 12m  
 Aperture Size: 5 – 90 mm



**Sand Making Machine**  
 Feed Size: <10  
 Capacity: 15-200tph  
 Diameter of Wheel Bucket: 2200 – 3600 mm

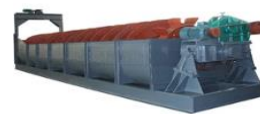

**Spiral Classifier**  
 Spiral Diameter: 300 – 3000 mm  
 Length of Pool: 3000– 14300mm  
 Rotating Speed: 30 – 3.2 rpm



**Hydrocyclone**  
 Feed Size: 16 – 0.6 mm  
 Feeding Pressure: 0.4 – 0.03Mpa  
 Capacity: 250 – 2 m3h  
 Range (um): 5 ~ 220

**CONVEYING SYSTEM**



**Mobile Belt Conveyor**  
 Belt Width: 400 – 1200 mm  
 Capacity: 40 – 1200 tph  
 Belt Speed: 0.8 – 2 m/s



**Belt Conveyor**  
 Belt Width: 500 – 1600 mm  
 Capacity: 20 – 1200 tph  
 Belt Speed: 0.8 – 2 m/s



**Large Angle Apron Belt**  
 Belt Width: 500 – 800 mm  
 Capacity: 104 - 430 m3h  
 Height of Apron: customer reqt



**Screw Conveyor**  
 Diameter of Screw: 163– 362 mm  
 Capacity: 25 – 120 tph  
 Rotary Speed: 308 – 170 rpm  
 Max Conveying Length: 15–25m



**Inclined Screw Conveyor**

Diameter of Tube:159 – 426 mm  
Capacity: 2 – 22 m3h  
Working Angle: 0-30  
Max Conveying Length:10–25m



**Vibratory Tube Conveyor**

Diameter of Tube:250 – 350 mm  
Working Angle: 0-5  
Conveying Distance: 3 – 7m



**Z Shape Bucket Elevator**

Diameter of Tube:250 – 350 mm  
Working Angle: 0-5  
Conveying Distance: 3 – 7m



**Bucket Elevator**

Bucket Capacity: 2.5 – 501.8 L  
Bucket Pitch: 203 – 800 mm  
Size of Material: 50 – 195 mm  
Capacity: 15 – 800 m3h

**EQUIPMENT SPARE PARTS**

**Gear Motor:** Cycloidal, SEW Type, Helical Gear, Industrial Helical Bevel, Planetary, NMRV Worm, Worm Gear, PIV Chain Variable Speed Drive



**Vibrating Motor:** ZSF Silo, YZUL Vertical, XUM, VB, YZO, YZ



**Jaw Crusher Spare Parts:**

The wearing parts of jaw crusher are mainly the movable jaw plate, fixed jaw plate, cheek plate and toggle plate. Can do different types of Spare Parts:

Metso, Sandvik, Parker, Terex Pegson, Terex Jaques, Terex Finlay, China: SBM, Shanghai Zenith, Henan Liming, Shuangquan, Shenyang, Vipeak, Yifan, etc. Terex, Komatsu, El Jay Rollercone, FINTEC, Cedar Rapids, Svedala, Maxtrak, Tesab, EXTEC



**Cone crusher Spare Parts:**

Main Frame, Head, Bowl Liner, Feed Plate, Bowl, Concave, Mantle. Can do different types of Spare Parts: Metso, Sandvik, Mingyu, Terex Pegson, Symons, Terex Finlay, China: SBM, Shanghai

Zenith, Henan Liming, Shuangquan, Shenyang, Vipeak, Yifan, etc. Terex, Komatsu, El Jay Rollercone, FINTEC, Cedar Rapids, Svedala, Maxtrak, Tesab, EXTEC

**Impact Crusher Spare Parts:**

Impact Bar, Impact Plate, Liner Plate, etc... Can do different types of Spare Parts: Hazmag, Metso, Kleeman, Terex Pegson/Terex Powerscreen, China: SBM, Shanghai Zenith, Henan Liming, Shanghai Longyang, Shanbao, etc. Rockster, Rubble Master, Strike, Parker, McCloskey, Tesab, Terex Finlay

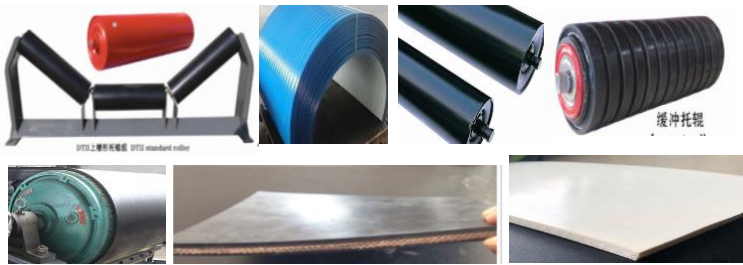

**Conveyor System Spare Parts:**

Conveyor Cover, UHMW-PE Roller, Conveyor Roller, Conveyor Pulley Conveyor Rubber Belt, Endless Rubber Belt, Chevron V, Side Wall, PVC Belt, Fastener Screw



**Screw Conveyor Spare Parts:**

Screw Blade, Universal Joint, Hanging Bearing, Reducer, End bearing



**Screening Spare Parts:** Stainless Steel Wire Mesh, Square Wire Mesh, Welded Wire Mesh, Crimped Wire Mesh, Perforated Metal, Wedge Wire Screen

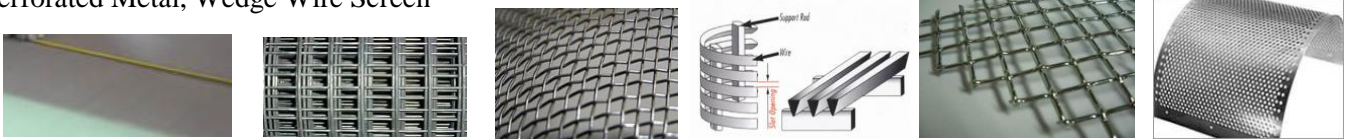

**Grinding Mill Spare Parts:**

Raymond mill, MTW / MTM / TGM / YGM mill wearing spare parts. Mill roller, Mill Ring, Shovel and shovel base, Bearing, Roller core, Spring for roller, Roller hanger, Main shaft, Classifier, Locking nut, Roller assembly, Snail shell, Motor, Elevator, Chain



**Ball Mill Spare Parts:**

Cast Grinding Ball, Forged Grinding Ball, Manganese Steel Ball Mill Liners, Rubber Liner Plate

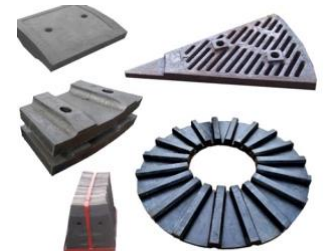

**ELECTRICAL SUPPLIES**

**Electrical Components**

Miniature Circuit Breaker (MCB), Distribution Box Plastic and Metal Flush and Surface Type, Moulded Case Circuit Breaker (MCCB), Air



Circuit Breaker, Surge Protector, Auxiliary Contact, Thermal Overload Relay, Magnetic Contactor, DOL Starter, Push Button, Selector Switch, Timers, Sockets, Micro Switch, Analog Panel Meter, Watt-Hour Meter, Current Transformer, Control Transformer. Home Safety Breaker, Switches and Outlet

### Electrical Conduit and Accessories

EMT/IMC/RSC Conduit Pipes and Elbows, Conduit Coupling and Connectors, Conduit Body, Entrance Cap, Conduit Bushing, Locknut, Steel Flexible Conduit and its Coupling and Connector, Liquid tight Flexible hose and its Coupling and Connector, Conduit Strap and Hanger, Loop and Clevis Hanger, Steel Junction, Utility and Square Box, Threaded Rod and Anchor Bolt, PVC Electrical Pipe and its Coupling and Connector, PVC Flexible Hose and its Coupling and Connector.







### Grounding System

Tape Clip, Cable Clamp, Ground Rod Clamp, Ubolt Ground Rod Clamp, Ground C clamp, Grounding Rod, Lighting Rod, Copper Bus Bar, Tower Clamp, Copper Tape, Exothermic Welding, Terminal Lugs.

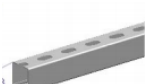

### Cable Tray and Accessories

					
<b>Cable Tray</b> Width: 50mm – 600mm Height: 15mm – 100mm Length: 2400mm / 3000mm	<b>Cable Ladder</b> Width: 100mm – 900mm Height: 50mm – 150mm Length: 2400mm / 3000mm	<b>Wire Mesh Cable</b> Width: 50mm – 600mm Height: 35mm – 100mm Length: 2400mm / 3000mm	<b>Cable Trunking</b> Width: 100mm – 600mm Height: 100mm – 200mm Length: 2400mm / 3000mm	<b>Strut Channel</b> Width : 21mm, 41mm Height : 21mm, 41mm Length : 3000mm Gauge 14 and 16	<b>WireWay</b> Width : 63.50, 102, 152mm Height : 63.50, 102, 152mm Length : 2440mm

## POWER TOOLS



Angle Grinder, Hand Drill, Impact Drill, Demolition Hammer, Rotary Hammer, Diamond Drill, Impact Wrench, Heat Gun, Marble Cutter, Circular Saw, Cut-Off Saw, Chain Saw, Palm Router, Blower, Self-Leveling Laser, Laser Distance Measure, Pressure Washer, Brushcutter, Air Compressor, Generator, Engine and other related Power Tools

## WELDING RODS AND ACCESSORIES

Mild Steel Rod: 6010, 6011, 6012, 6013  
Low Hydrogen High Tensile Steel: 7018, 9018  
Stainless Steel: 308, 312, 316  
Hard Surfacing: 300, 600 / Cast Iron: 100, 50 / Champer Cutting

MIG Wire / TIG Fille Wire / Flux Cored Wire / Tungsten Electrodes / SAW Wire and Flux

Accessories: Gloves, Apron, Welding Mask, Cable Wire, Electrode Holder



# ROAD MARKING PAINT AND MACHINE



**hot melt reflective coating:**

Thermoplastic road marking paint consists of resin , EVA, PE wax, fillers materials, glass bead, which is solid powder condition at normal temperature. If it is heated to 180-200 degrees by heat at fusing pot under construction. it will appears flowage, coating pot under construction, it will appears flowage, coating the paint to the road surface will form hard film, It has full line type, strong wearing resistance and other flowage. Sprinkling reflecting glass micro beads on the surface under construction, it has good reflecting effect at night. It is widely applied in highway and road. According to the environment used and the different construction requirements, we can supply different types of paint for our customer option.

**FEATURES**

- Strong adhesion strength:** Resin content is reasonable, and it was added special rubber elastomer in the primer, so it has strong adhesion strength . If the construction technique is reasonable, there is no peeling off.
- Good cracking resistance:** Thermoplastic line marking is easy to form crack because of the temperature variation of thermoplastic line marking.
- Bright color:** The paint adopts the color of the highest level with reasonable proportion, so it has good weather resistance and will not change color if long term exposure.
- High usage ratio:** The major feature of paint is low density, big volume and high usage ratio.
- Good dirt resistance:** The dosage and quality of PE wax are the key point of impacting the dirt resistance. PE wax of Exxon is our first choice for many years.

**THEORETICAL DOSAGE:**

Coating weight	Coating thickness	Spreading area	Bottom oil consumption	Glass bead content
1tons	1.8mm	225 Square meter	32kg	100kg



■ The paint heating



■ High speed engineering case



■ High speed engineering case



■ City Road marking

## Specification of Thermoplastic Road Marking Paint

We can adjust the formula of paint to meet customers' local climate!



Coating thickness	1.8-2.0mm
Ingredient	CS Petropols, EVA, PE wax, titanium dioxide, filler materials
Heating Temperature	180-200°C
Dry Time After Marking	3mins(full dry: 10 mins)
Softening Temperature	90-125°C
Glass Beads Content	0%/10%/20%/25%/>30%

**Other Types of Paint :**  
Cold Solvent Paint,  
MMA Two Component,  
Colorful Non-Slip Road  
Marking Paint

## Auxiliary Machine



Thermoplastic Road Marking



Preheater



Hand Push Thermoplastic Road Marking Machine



Automatic Road Marking Machine



Vibrating Road Marking Machine

Airless Cold Paint Road Marking



Single Gun



Double Guns



Double Guns + Glass Bead Dispenser

## ROAD MARKING SIGNS AND SAFETY



# CONSTRUCTION

## WHAT WE DO

With a professional team of builders, our aim is to provide integrated construction services in civil, structural, architectural, mechanical and electrical works.



### PRE-CONSTRUCTION

- Planning and Design



### CIVIL, ARCHITECTURAL, STRUCTURAL

- Earthworks
- Concreting, Rebar & Formworks
- Masonry Works
- Carpentry Works
- Structural Steel Works
- Thermal & Moisture Protection
- Architectural Finishes & Interior Fit-outs
- Water Proofing Works
- Painting Works



### PLUMBING & SANITARY WORKS

- Main Water Supply
- Cold & Hot Water line
- Sanitary & Sewer System
- Drainage System



### ELECTRICAL WORKS

- Power Supply and Distribution
- Lighting Protection System and Ground System
- Fire Detection and Alarm System
- Low to Medium Voltage System
- Power Transformers



### MECHANICAL WORKS

- Heating, Ventilation and Air Conditioning System
- Elevator and Escalators Systems
- Compressed Air and Vacuum System
- Fire Protection System
- Process Machinery



### OTHER ENGINEERING AND BUILDING WORKS

## Installation, Repair and Maintenance Services for Processing Machinery Equipment's

### CRUSHING PLANT

Crushers are machines used to reduce the size of rocks, stones and ore. They are often utilized in aggregates production, construction material recycling and in mining operations.

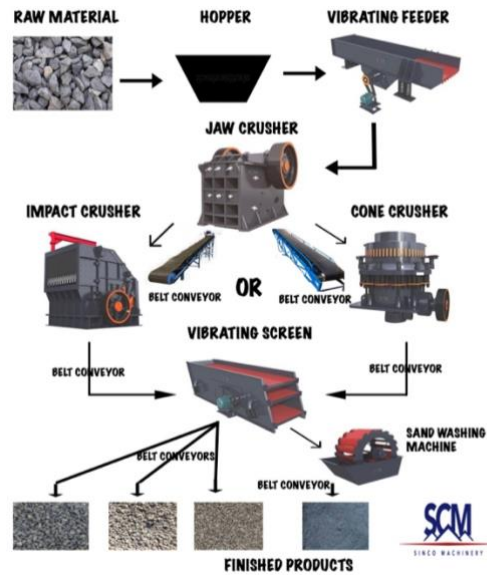

### BLOCK MAKING MACHINE

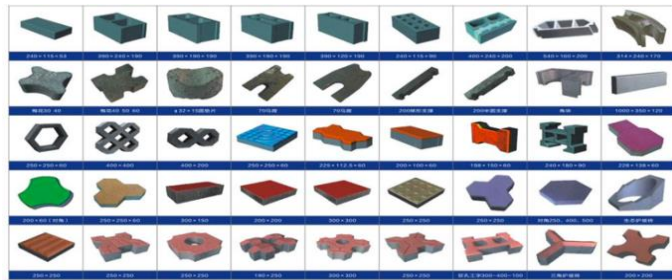

### GOLD ORE SEPARATION:

#### A. Gold CIP/CIL Flow –

The CIL process and the CIP process belong to the cyanidation gold extraction process, which are mainly developed by using activated carbon with the excellent characteristics of gold adsorption.

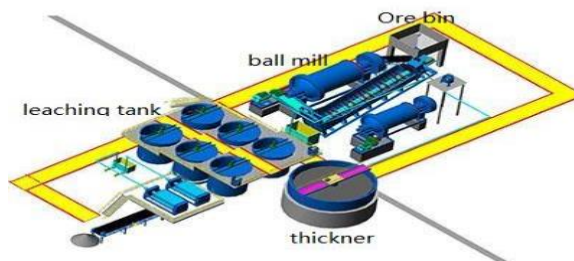

**Carbon pulp method (CIP):** cyanide leaching is done first, then activated carbon is used to adsorb gold in the pulp;

**Carbon leaching method (CIL):** activated carbon is added to the leaching tank, and leaching and adsorption are carried out simultaneously, that is, soaking and sucking.

## COPPER ORE SEPARATION:

### A. COPPER ORE FLOTATION PLANT

This equipment is a piece of equipment mainly used by Copper Ore Flotation Plant and mainly used in the copper processing industry.

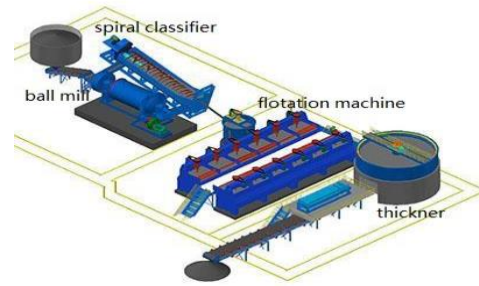

### B. COPPER ORE GRAVITY SEPARATION PROCESS

Copper Ore Gravity Separation Process is one of the methods of beneficiation of copper ore. It is a method of beneficiating ore according to the difference of mineral density, and it occupies an important position in the method of beneficiation..



## ENGINEERING PROCUREMENT CONSTRUCTION (EPC)

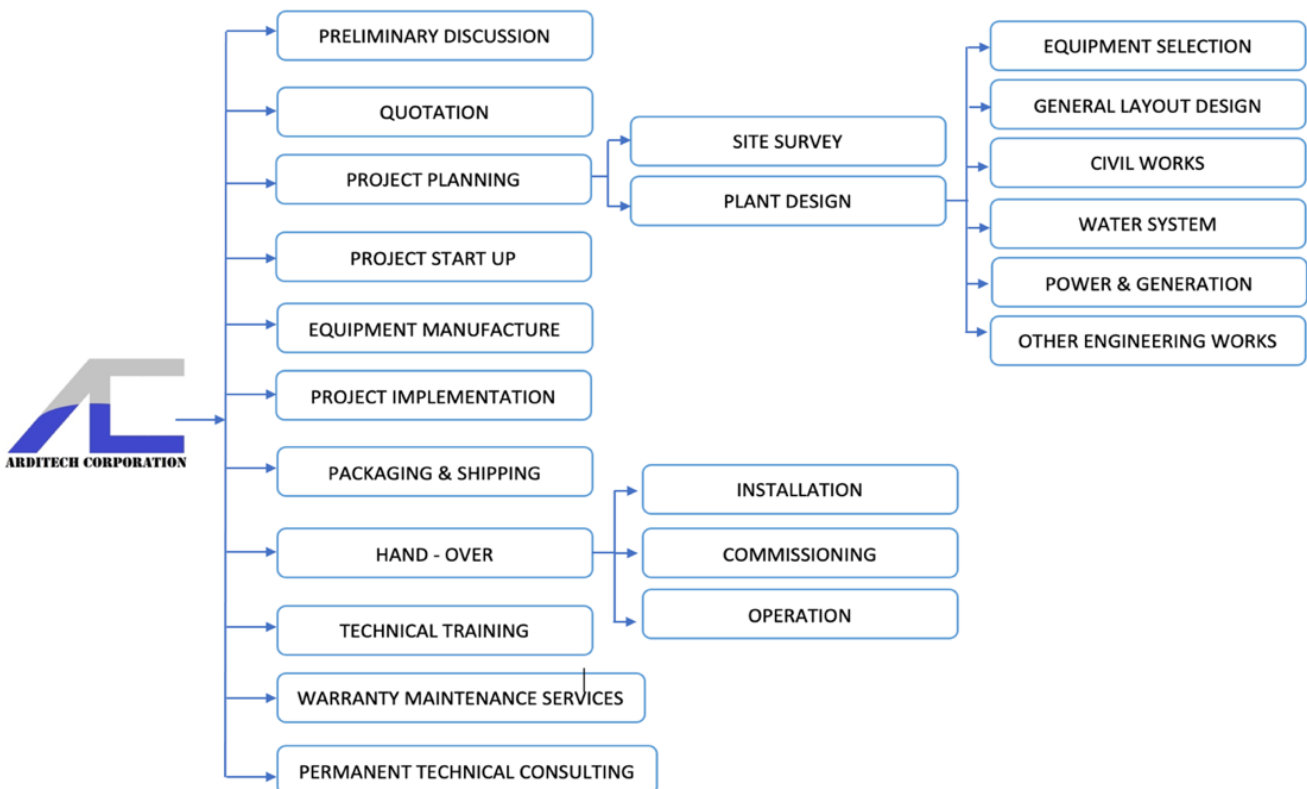

We also have **ORE SAMPLE TESTING/COLLECTION** (Laboratory Testing and Beneficiation Testing)



# Business permits

# SEC CERTIFICATE



REPUBLIC OF THE PHILIPPINES  
**SECURITIES AND EXCHANGE COMMISSION**  
THE SEC HEADQUARTERS  
7907 Makati Avenue, Salcedo Village,  
Barangay Bel-Air, Makati City, 1209

**TARLAC CITY EXTENSION OFFICE**  
Tarlac City

COMPANY REG. NO. CS202009183

**CERTIFICATE OF FILING  
OF  
AMENDED ARTICLES OF INCORPORATION**

**KNOW ALL MEN BY THESE PRESENTS:**

**THIS IS TO CERTIFY** that the amended articles of incorporation of the

**ARDITECH CORPORATION**  
(Amending Articles II and VII thereof)

copy annexed, adopted on **January 31, 2023** by majority vote of the Board of Directors and by the vote of the stockholders owning or representing at least two-thirds of the outstanding capital stock, and certified under oath by the Corporate Secretary and a majority of the Board of Directors of the corporation, was approved by the Commission on this date pursuant to the provision of Section 15 of the Revised Corporation Code of the Philippines, Republic Act No. 11232, which took effect on February 23, 2019, and copies thereof are filed with the Commission.

Unless this corporation obtains or already has obtained the appropriate Secondary License from this Commission, this Certificate does not authorize it to undertake business activities requiring a Secondary License from this Commission such as, but not limited to acting as: broker or dealer in securities, government securities eligible dealer (GSED), investment adviser of an investment company, close-end or open-end investment company, investment house, transfer agent, commodity/financial futures exchange/broker/merchant, financing/lending company and time shares/club shares/membership certificates issuers or selling agents thereof; nor to operate a fiat money to virtual currency exchange. Neither does this Certificate constitute as permit to undertake activities for which other government agencies require a license or permit.

**IN WITNESS WHEREOF**, I have set my hand and caused the seal of this Commission to be affixed to this Certificate at 2F Legislative Bldg., City Hall, Tarlac City, Tarlac, Philippines, this **08<sup>th</sup>** day of May Two Thousand Twenty-Three.

**By the Authority of the Commission:**

  
**RICHARD R. LAUS**  
Director



REPUBLIC OF THE PHILIPPINES  
SECURITIES AND EXCHANGE COMMISSION  
THE SEC HEADQUARTERS  
7907 Makati Avenue, Salcedo Village,  
Barangay Bel-Air, Makati City, 1209

TARLAC CITY EXTENSION OFFICE  
Tarlac City

COMPANY REG. NO. CS202009183

**CERTIFICATE OF APPROVAL OF INCREASE OF CAPITAL STOCK**

KNOW ALL MEN BY THESE PRESENTS:

THIS IS TO CERTIFY that the increase of capital stock of the

**ARDITECH CORPORATION**

from P500,000.00 divided into 500,000 shares of the par value of P1.00 each to P32,500,000.00 divided into 32,500,000 shares of the par value of P1.00 each, approved by a majority of the Board of Directors and by the vote of the stockholders owning or representing at least two-thirds of the outstanding capital stock at a meeting held on January 31, 2023 certified to by the Chairman and the Secretary of the stockholders meeting and a majority of the Board of Directors of the corporation, was approved by the Commission on the date indicated hereunder in accordance with the provision of Section 37 of the Revised Corporation Code of the Philippines, Republic Act No. 11232, which took effect on February 23, 2019. A copy of the Certificate of Increase of Capital Stock filed with the Commission is attached hereto.

IN WITNESS WHEREOF, I have set my hand and caused the seal of this Commission to be affixed to this Certificate at 2F Legislative Bldg., City Hall, Tarlac City, Tarlac, Philippines, this 08<sup>th</sup> day of May Two Thousand Twenty-Three.

By the Authority of the Commission:

  
RICHARD R. LAUS  
Director

# MAYOR'S PERMIT



REPUBLIC OF THE PHILIPPINES  
CITY GOVERNMENT OF MANILA  
OFFICE OF THE MAYOR  
BUREAU OF PERMITS



## ELECTRONIC BUSINESS PERMIT –RENEWAL

<b>Owner's Name:</b> ARDITECH CORPORATION	<b>BIN:</b> 117-00-2021-0100138
<b>Business Name:</b> ARDITECH CORPORATION	<b>Permit No.:</b> 2024-000016947
<b>Address:</b> RIZAL AVE., 2163, BARANGAY 358, SANTA CRUZ, NCR, CITY OF MANILA, FIRST DISTRICT, 1014	<b>eOR No.:</b> OR-2024-0017322-B
<b>Telephone No.:</b> 0282519991	<b>Date:</b> 01/17/2024
<b>Email Address:</b> Arditechcorporation@gmail.com	<b>Time:</b> 02:13:10 PM
<b>No. of Emp.:</b> 4	<b>Amount Paid:</b> 68,181.05
<b>Area:</b> 39.00	<b>Barangay No.:</b> 358
<b>Nationality:</b>	

KIND OF BUSINESS	PERMIT FEES	REMARKS
0226 WSALE INDL SUPPLIES	1,500.00	Subject to compliance and post-inspection. Non-compliance of any city regulations may lead to Cancellation/Revocation of this permit. For application and issuance of Safety Seal Certificate within a period of ninety (90) days. To apply on-line for Safety Seal, Proceed to <a href="https://www.gomanila.com">https://www.gomanila.com</a> . MUST INSTALL CCTV AS PER ORDINANCE NO. 8173 W/IN 60 DAYS. (If applicable or stated in the ordinance)
07171 GEN CONTR	1,500.00	

**SUBJECT TO INSPECTION**

"THIS SERVES AS YOUR OFFICIAL BUSINESS PERMIT, NO NEED TO CLAIM ANY DOCUMENTS AT THE BUREAU OF PERMITS, MANILA CITY HALL"

# BIR REGISTRATION 2303

BIR FORM  
**2303**  
REVISED: APRIL 2019



OCN: 031RC20230000001631  
Date OCN Generated: June 6, 2023

## CERTIFICATE OF REGISTRATION

<b>TIN &amp; BRANCH CODE</b> 010-539-001-00000	<b>NAME OF TAXPAYER</b> ARDITECH CORPORATION	<b>TIN ISSUANCE DATE</b> November 4, 2020
<b>REGISTERING OFFICE</b>	<input checked="" type="checkbox"/> Head Office	<input type="checkbox"/> Branch
<b>REGISTERED ADDRESS</b> 2163 RIZAL AVENUE BARANGAY 358 ZONE 36 1014 SANTA CRUZ NCR, CITY OF MANILA, FIRST DISTRICT PHILIPPINES		

TAX TYPES	FORM TYPES	FILING START DATE	FILING FREQUENCY	FILING DUE DATE
CORPORATE INCOME TAX	1702Q	January 14, 2021	QUARTERLY	Within sixty (60) days following the close of each of the first three (3) quarters of the taxable year.
CORPORATE INCOME TAX	1702	January 14, 2021	ANNUALLY	On or before the 15th day of the 4th month following the close of the taxpayer's taxable year.
REGISTRATION FEE	0605	January 14, 2021		On or before the last day of January.
VALUE ADDED TAX	2550Q	January 14, 2021	QUARTERLY	Not later than the 25th day following the close of each taxable quarter.
WITHHOLDING TAX - COMPENSATION	1601C	January 14, 2021	MONTHLY	On or before the 10th day of the month following the month when the withholding was made except for taxes withheld for December which shall be filed and paid/remitted on or before January 15 of the succeeding year.
WITHHOLDING TAX - COMPENSATION	1604C	January 1, 2024	ANNUALLY	On or before January 31 of the year following the calendar year in which the compensation payment and other income payments were paid or accrued.
WITHHOLDING TAX - EXPANDED/OTHERS	1601EQ	January 14, 2021	QUARTERLY	Not later than the last day of the month following the close of the quarter during which withholding was made.
WITHHOLDING TAX - EXPANDED/OTHERS	0619E	January 14, 2021	MONTHLY	On or before the 10th day of the month following the month in which withholding was made.
WITHHOLDING TAX - EXPANDED/OTHERS	1604E	January 14, 2021	ANNUALLY	On or before March 1 of the year following the calendar year in which the income payments subject to expanded withholding taxes or exempt from withholding tax were paid or accrued.

**BIR FORM**  
**2303**  
REVISED: APRIL 2019

REPUBLIKA NG PILIPINAS  
KAGAWARAN NG PANANALAPI  
KAWANIHAN NG RENTAS INTERNAS  
REVENUE REGION NO. 006 - CITY OF MANILA  
REVENUE DISTRICT OFFICE NO. 031 - STA. CRUZ

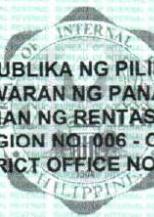

OCN: 031RC2023000001631  
Date OCN Generated: June 6, 2023

**CERTIFICATE OF REGISTRATION**

<b>TIN &amp; BRANCH CODE</b> 010-539-001-00000	<b>NAME OF TAXPAYER</b> ARDITECH CORPORATION	<b>TIN ISSUANCE DATE</b> November 4, 2020
<b>REGISTERING OFFICE</b>	<input checked="" type="checkbox"/> Head Office	Branch
<b>REGISTERED ADDRESS</b> 2163 RIZAL AVENUE BARANGAY 358 ZONE 36 1014 SANTA CRUZ NCR, CITY OF MANILA, FIRST DISTRICT PHILIPPINES		

<b>TAXPAYER TYPE/S</b>	DOMESTIC CORPORATION
------------------------	----------------------

BUSINESS INFORMATION DETAILS		CATEGORY	REGISTRATION DATE
<b>TRADE NAME 1</b> (PSIC)	<b>ARDITECH CORPORATION</b> 42900-CONSTRUCTION OF OTHER CIVIL ENGINEERING PROJECTS	Primary	November 4, 2020
<b>Line of Business</b> (PSIC)	CONSTRUCTION OF BUILDINGS		
<b>Line of Business</b> (PSIC)	43900-OTHER SPECIALIZED CONSTRUCTION ACTIVITIES	Secondary	
<b>Line of Business</b> (PSIC)	OTHER SPECIALIZED CONSTRUCTION ACTIVITIES		
<b>Line of Business</b> (PSIC)	46592-WHOLESALE OF INDUSTRIAL MACHINERY AND EQUIPMENT	Secondary	
<b>Line of Business</b> (PSIC)	WHOLESALE OF INDUSTRIAL MACHINERY AND EQUIPMENT		

- REMINDERS:**
1. An annual registration fee shall be paid upon registration and every year thereafter on or before the last day of January, using BIR Form No. 0605.
  2. Filing of required tax return/s to conform with the above tax types, whether with or without business operation, to avoid penalties.
  3. For new business registrants, application for registration of manual Books of Accounts (B/As) shall be before the deadline for filing of the initial quarterly income tax return or annual income tax return whichever comes earlier, from the date of registration. Registration of new set of manual B/As shall be before its use.
  4. Immediately inform the district office in case of transfer/cessation of business and other changes in registration information by filing BIR Form No. 1905.
  5. For Self-Employed Individuals (SEI) whose gross sales and/or receipts and other non-operating income does not exceed P3,000,000 and who opted to avail of the 8% Income tax rate, the tax type Percentage Tax (PT) shall not be reflected in the Certificate of Registration (COR). However, at the start of each taxable year, such SEI shall be automatically subjected to graduated income tax rates and required to file quarterly percentage tax return (BIR Form No. 2551Q) and option to replace the COR to reflect "PT", unless qualified and opted to avail of the 8% Income tax rate annually.

**BIR FORM**  
**2303**  
REVISED: APRIL 2019

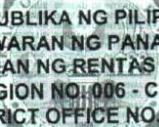
  
**REPUBLIKA NG PILIPINAS**  
**KAGAWARAN NG PANANALAPI**  
**KAWANIHAN NG RENTAS INTERNAS**  
**REVENUE REGION NO. 006 - CITY OF MANILA**  
**REVENUE DISTRICT OFFICE NO. 031 - STA. CRUZ**

**OCN: 031RC2023000001631**  
**Date OCN Generated: June 6, 2023**

**CERTIFICATE OF REGISTRATION**

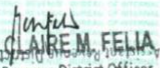
<b>TIN &amp; BRANCH CODE</b> 010-539-001-00000	<b>NAME OF TAXPAYER</b> ARDITECH CORPORATION	<b>TIN ISSUANCE DATE</b> November 4, 2020
<b>REGISTERING OFFICE</b>	<input checked="" type="checkbox"/> Head Office	Branch
<b>REGISTERED ADDRESS</b> 2163 RIZAL AVENUE BARANGAY 358 ZONE 36 1014 SANTA CRUZ NCR, CITY OF MANILA, FIRST DISTRICT PHILIPPINES		
<b>RDO DRY SEAL</b>	<p>I hereby certify that the above named person is registered as indicated above, under the provision of the National Internal Revenue Code, as amended.</p> <p align="right">   <b>MARIE CLAIRE M. FELIA</b>                      Assistant Revenue District Officer  <b>REBE D. DETABLAN</b> </p> <p align="center"> <b>REVENUE DISTRICT OFFICER</b>                      (Signature over Printed Name)                 </p>	

**THIS CERTIFICATE MUST BE EXHIBITED CONSPICUOUSLY IN THE PLACE OF BUSINESS.**

# PCAB LICENSE 2023-2024







Republic of the Philippines  
DEPARTMENT OF TRADE & INDUSTRY  
CONSTRUCTION INDUSTRY AUTHORITY OF THE PHILIPPINES  
**PHILIPPINE CONTRACTORS ACCREDITATION BOARD**  
Makati City, Metro Manila, Philippines

## REGULAR CONTRACTOR'S LICENSE

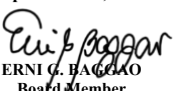
FORM NUMBER: **49081**

Contracting Fiscal Year (CFY): **2024/2025**

<p>This certifies that</p> <p><b>ARDITECH CORPORATION</b></p> <p>having complied with all the requirements for licensure pursuant to Republic Act No. 4566 (as amended) and its implementing rules and regulations, is hereby authorized to engage in the construction contracting business in the Philippines, subject to herein limitations of license validity period, classification and category as prescribed under License Particulars in the box to the right and to the terms and conditions annotated at the back hereof.</p> <p>This further certifies that said licensee, subject to the limitations of the above-prescribed license validity period and registration validity period, kind/s of project and size range/s as indicated under Registration Particulars in the box to the right hereof, is a PCAB registered contractor for government projects.</p> <p>Given at Metro Manila, Philippines, on September 04, 2024</p> <p> ERNI G. BAGAO Board Member</p> <p> HERBERT G. MATIENZO Executive Director</p> <p> SERGIE T. RETOME Board Secretary</p> <p></p> <p>DOCUMENTARY STAMP TAX PAID (Php 30.00)</p>	<p><b>CONTRACTOR'S PARTICULAR</b></p> <p>Authorized Managing Officer Signature <small>NOT VALID WITHOUT SIGNATURE</small></p> <p><b>MICHELLE MAE ZAMORA RAMOS</b></p> <p>Organization Type Head Office (Region)</p> <p><b>Corporation</b> <b>NCR (National Capital Region)</b></p> <p>Taxpayer Identification Number (TIN)</p> <p><b>010539001</b></p> <p><b>LICENSE PARTICULARS</b></p> <p>License First Issue Date Contractor's License Number</p> <p><b>October 09, 2023</b> <b>55990</b></p> <p>Validity Period of this License/Renewal</p> <p><b>October 09, 2024 to October 09, 2025</b></p> <p>Principal Classification and Category</p> <p><b>General Building</b> <b>D</b></p> <p>Other Classification/s General Engineering Specialty-Electrical Work Specialty-Waterproofing Work Specialty-Painting Work oooooooooooooooooooooooooooo</p> <p></p>																		
	<p><b>REGISTRATION PARTICULARS</b></p> <p>Registration Date Registration Number</p> <p><b>October 09, 2023</b> <b>3958-2023</b></p> <p>Validity Period of this Registration</p> <p><b>October 09, 2023 to October 09, 2026</b></p> <p>Kinds of Project and Respective Size Ranges</p> <table border="0"> <tr><td>Building and Industrial Plant</td><td>Small B</td></tr> <tr><td>Road, Highway, Pavement, Railways, Airport Horizontal</td><td>Small B</td></tr> <tr><td>Structures and Bridges</td><td></td></tr> <tr><td>Water Treatment Plant and System</td><td>Small B</td></tr> <tr><td>Park, Playground and Recreational Work</td><td>Small B</td></tr> <tr><td>Sewerage and Sewage Treatment/Disposal Plant</td><td>Small B</td></tr> <tr><td>Electrical Work</td><td>Small B</td></tr> <tr><td>Waterproofing Work</td><td>Small B</td></tr> <tr><td>Painting Work</td><td>Small B</td></tr> </table>	Building and Industrial Plant	Small B	Road, Highway, Pavement, Railways, Airport Horizontal	Small B	Structures and Bridges		Water Treatment Plant and System	Small B	Park, Playground and Recreational Work	Small B	Sewerage and Sewage Treatment/Disposal Plant	Small B	Electrical Work	Small B	Waterproofing Work	Small B	Painting Work	Small B
	Building and Industrial Plant	Small B																	
	Road, Highway, Pavement, Railways, Airport Horizontal	Small B																	
	Structures and Bridges																		
	Water Treatment Plant and System	Small B																	
	Park, Playground and Recreational Work	Small B																	
	Sewerage and Sewage Treatment/Disposal Plant	Small B																	
	Electrical Work	Small B																	
	Waterproofing Work	Small B																	
Painting Work	Small B																		

IMPORTANT NOTICE: Filing schedule for license renewal application – on or before **September 09, 2025**

# TAX CLEARANCE 2023



REPUBLIC OF THE PHILIPPINES  
DEPARTMENT OF FINANCE  
BUREAU OF INTERNAL REVENUE  
REVENUE REGIONAL OFFICE  
QF-TCC-01-01-2023.00

TCCBP NO.06-031-05-29-R0658-2024-M

## TAX CLEARANCE CERTIFICATE (Pursuant to Executive Order No. 398) ARDITECH CORPORATION

Name of Taxpayer

2163 RIZAL AVENUE, BARANGAY 358, ZONE 36, 1014, SANTA CRUZ NCR, CITY OF  
MANILA, FIRST DISTRICT, PHILIPPINES

Address

**010-539-001-00000**  
Taxpayer Identification Number

This is to certify that the above mentioned taxpayer is eligible for issuance of this Tax Clearance Certificate having satisfied all the criteria set forth by the BIR as of the date of this certification pursuant to Revenue Regulations No. 8-2016, as amended.

Tax liabilities recorded after the aforesaid dates or outside the jurisdiction of this Office are not covered by this tax clearance.

Issued this 29th day of May, 2024

NOTE: THIS CERTIFICATE SHALL BE VALID AND EFFECTIVE FROM DATE OF ISSUE UNTIL MAY 29, 2025 ONLY OR UNTIL REVOKED FOR VIOLATION OF THE CRITERIA SPECIFIED UNDER REVENUE REGULATIONS NO. 8-2016, AS AMENDED AND REVENUE MEMORANDUM ORDER NO. 46-2018, WHICHEVER COMES EARLIER. THIS SHALL NOT BE USED ON SALES/TRANSFER OF REAL PROPERTIES. CERTIFICATION FEE OF P100 WAS PAID ON MAY 25, 2024 UNDER EFPS PAYMENT TRANSACTION NO. 241855488. ANY ERASURE MADE ON THIS TCC SHALL RENDER IT NULL AND VOID.



**ENRIQUE REMIGIO Z. GATCHALIAN**  
Chief, Collection Division



WARNING: Counterfeiting is punishable by law. For authenticity, please visit BIR website [www.bir.gov.ph/index.php/tax-clearance/released-tax-clearance.html](http://www.bir.gov.ph/index.php/tax-clearance/released-tax-clearance.html). Tax Clearance Certificate (for bidding purposes) not listed/posted herein will be deemed to have originated from an illegal source.

# COMPLETED PROJECTS



**SS11 LANCASTER NEW CITY GENERAL TRIAS, CAVITE**

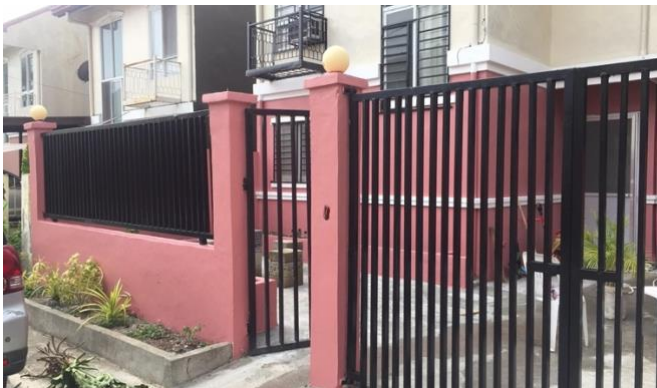

**PROJECT COST**

PHP 500,000.00

SCOPE OF WORK:

INTERIOR AND EXTERIOR FIT-OUTS

LIGHTING SYSTEM

PAINTING WORKS

LANDSCAPING

**CONTINUATION OF THREE STOREY 18 UNITS  
COMMERCIAL/RESIDENTIAL BUILDING WITH PASSABLE  
ROOFDECK  
DMC BLDG 1, GEN T. DE LEON VALENZUELA CITY**



**PROJECT COST**

PHP 12,000,000.00

SCOPE OF WORK:

ARCHITECTURAL, CIVIL, STRUCTURAL

PLUMBING AND SANITARY

ELECTRICAL & LIGHTING SYSTEM

FIRE DETECTION ALARM SYSTEM & CCTV SYSTEM

**CONSTRUCTION OF FOUR STOREY 18 UNIT  
COMMERCIAL/RESIDENTIAL BUILDING  
DMC BLDG 2, A. PABLO VALENZUELA CITY**



**PROJECT COST**

PHP 18,000,000.00

SCOPE OF WORK:

ARCHITECTURAL, CIVIL, STRUCTURAL

PLUMBING AND SANITARY

DRY STAND PIPE

ELECTRICAL & LIGHTING SYSTEM

FIRE DETECTION ALARM SYSTEM & CCTV SYSTEM

## CONSTRUCTION OF FIVE STOREY RESIDENTIAL WITH ROOFDECK AND ELEVATOR PROVISION JOSEFINA ST. GRACE PARK, CALOOCAN CITY



### PROJECT COST

PHP 25,000,000.00

SCOPE OF WORK:

ARCHITECTURAL, CIVIL, STRUCTURAL

PLUMBING AND SANITARY

ELECTRICAL & LIGHTING SYSTEM

**SUPPLY AND INSTALL  
SOLAR STREET LAMP  
LOADING BAY – EAGLE CEMENT CORPORATION  
BRGY. AKLE SAN ILDEFONSO, BULACAN**



**PROJECT COST**

PHP 603,000.00

SCOPE OF WORK:

SUPPLY AND INSTALL OF SOLAR LIGHTS AND SOLAR STREET LIGHT

**LABOR AND MATERIALS**  
**SELF-LEVELING EPOXY in 208 square meter**  
**HALLWAY - TECHNOLOGICAL UNIVERSITY OF THE PHILIPPINES**  
**AYALA BLVD., ERMITA, MANILA**

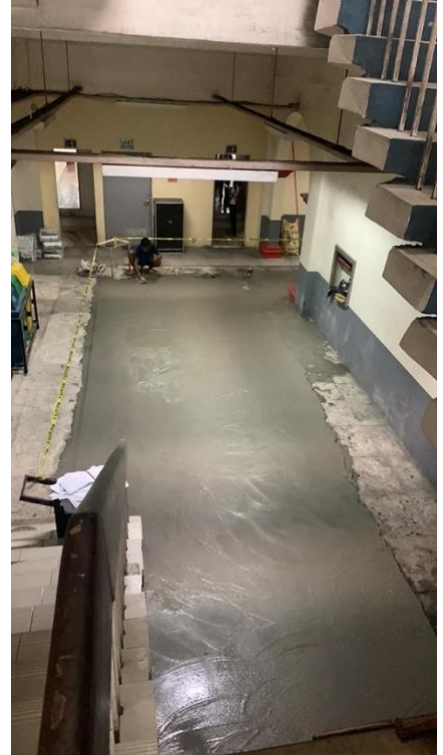

**PROJECT COST**  
PHP  
272,000.00  
**SCOPE OF WORK:**  
CHIPPING OF  
ROUGH EDGES,  
EPOXY FLOORING

**LABOR AND MATERIALS**  
**SELF-LEVELING EPOXY in 111.32 square meter**  
**CANTEEN - TECHNOLOGICAL UNIVERSITY OF THE PHILIPPINES**  
**AYALA BLVD., ERMITA, MANILA**

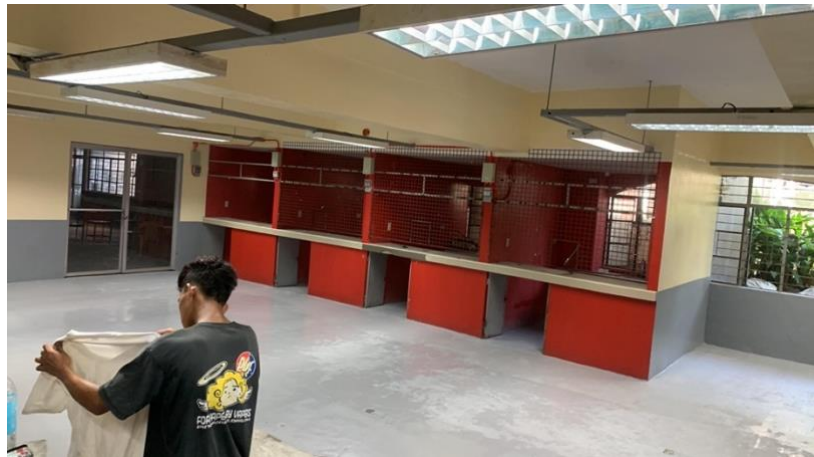
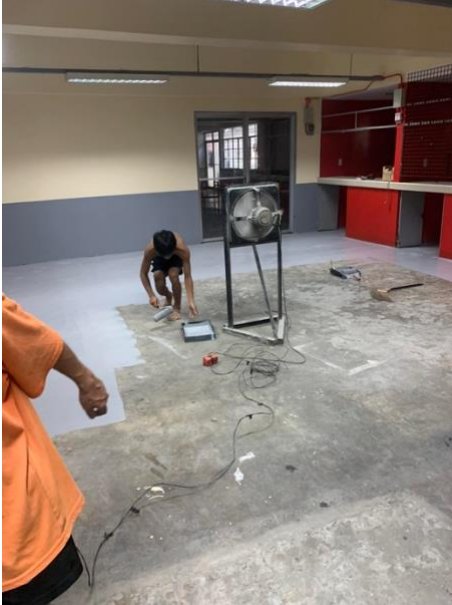

**PROJECT COST**  
PHP  
235,744.00  
SCOPE OF WORK:  
EPOXY FLOORING

**LABOR AND MATERIALS**  
**For TOWER 3 Lobby Refresh**  
**PITX, 1 Kennedy Road Brgy. Tambo Paranaque City**

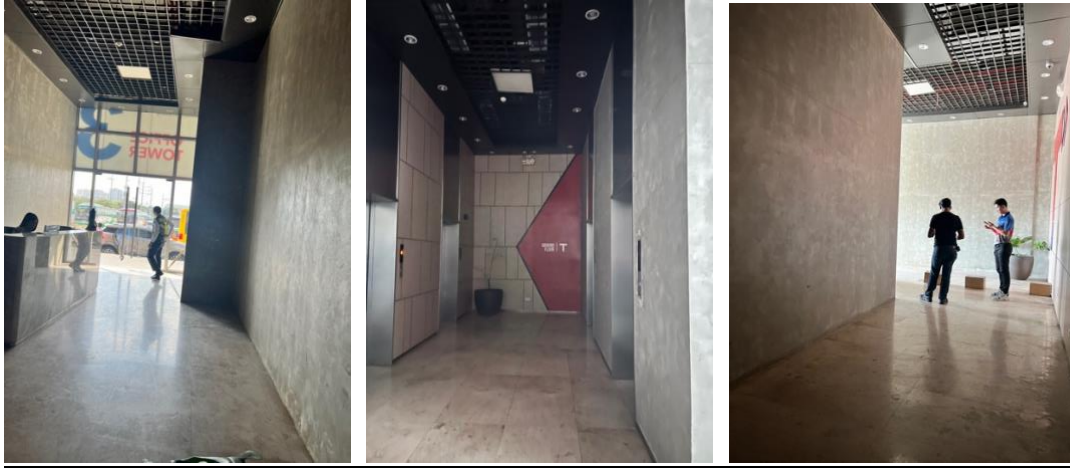

**PROJECT COST**  
PHP  
975,000.00  
**SCOPE OF WORK:**  
CIVIL,  
ARCHITECTURAL,  
ELECTRICAL

**LABOR AND MATERIALS**  
**For Tower 2 – Suntrust Dorm**  
**PITX, 1 Kennedy Road Brgy. Tambo Paranaque City**

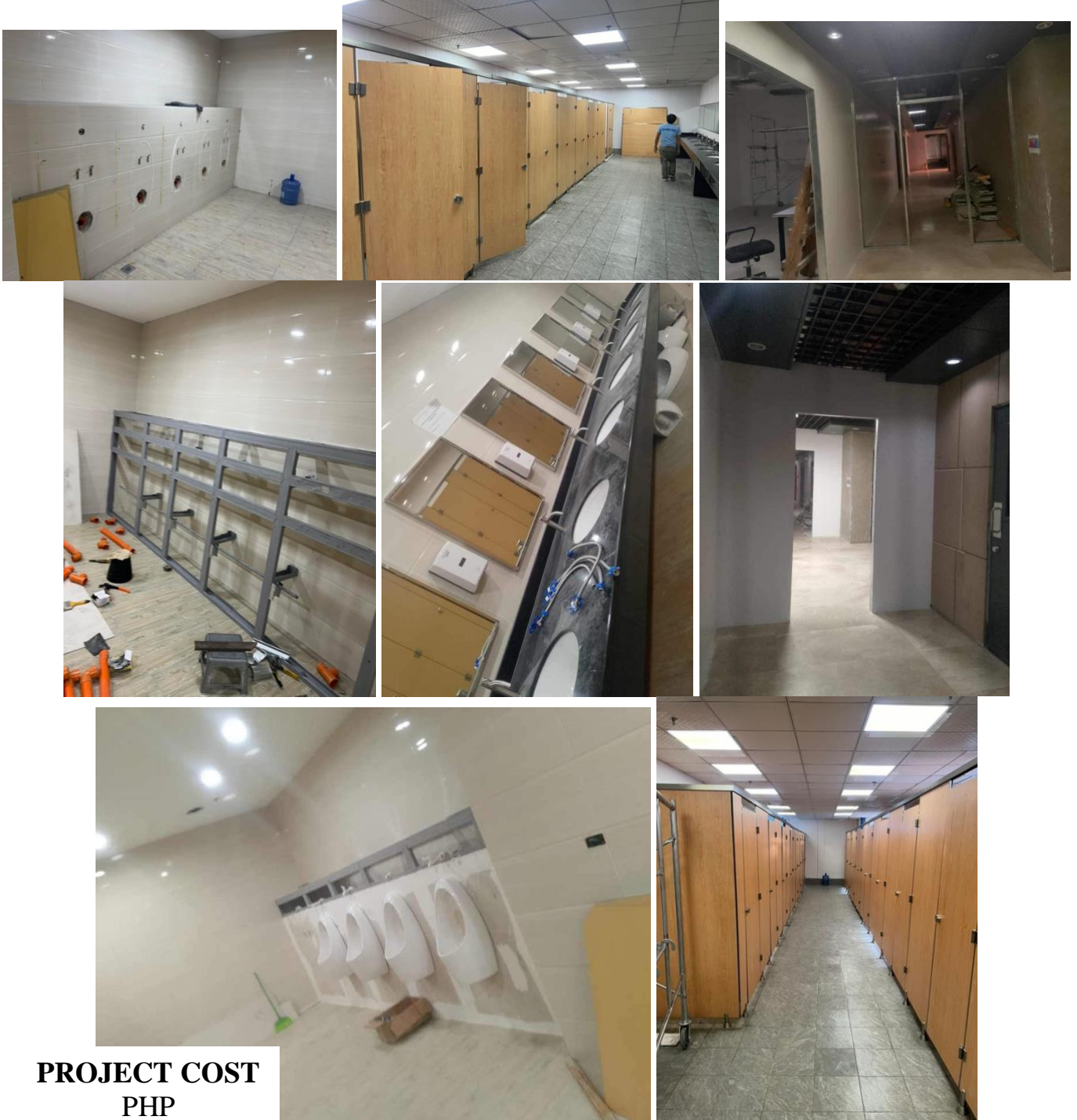

**PROJECT COST**  
PHP  
910,000.00  
**SCOPE OF WORK:**  
CIVIL, PLUMBING  
ELECTRICAL



IN CHRIST ALONE  
JOHN 3:16



“LOOKING FORWARD TO WORK WITH YOU!”

*“Each of you should use whatever gift you have received to serve others, as faithful stewards of God’s grace in its various forms” - 1Peter 4:10 (NIV)*



2163 Rizal Ave. Cor. A. Lorenzo Jr. St.  
Sta Cruz, Manila



(02) 8251-9991



+63917-709-9515



arditechsales@gmail.com  
arditechcorporation@gmail.com



www.arditechcorp.com